

VARIOKIT Engineering Construction Kit

System solutions for bridge, tunnel and civil engineering construction



Edition 04 | 2013

PERI GmbH
Formwork Scaffolding Engineering

Rudolf-Diesel-Strasse 19
89264 Weissenhorn
Germany
Tel. +49 (0) 7309.950-0
Fax +49 (0) 7309.951-0
info@peri.com
www.peri.com

Important Notes:

Without exception, all current safety regulations must be observed in those countries where our products are used.

The photos shown in this brochure feature construction sites in progress. For this reason especially safety and anchor details cannot always be considered as conclusive or final. These are subject to the risk assessment carried out by the contractor.

The systems or items shown are not necessarily available in all countries.

Safety instructions and load specifications are to be strictly observed at all times. Separate structural calculations are required for any deviations from the standard design data.

The information contained herein is subject to technical changes in the interests of progress. Errors and typographical mistakes reserved.

Content

VARIOKIT Engineering Construction Kit

- 2 System solutions for bridge, tunnel and civil engineering construction
- 4 Engineering services and materials from one source
- 6 Rentable standard system components

VARIOKIT for tunnel construction

- 8 Cut-and-cover, semi-monolithic construction method
- 10 Cut-and-cover, separate casting method
- 12 Mining, semi-monolithic construction method
- 14 Mining, separate casting method

VARIOKIT for bridge construction

- 16 Parapet track
- 18 Parapet carriage
- 20 Parapet bracket
- 22 Steel composite carriage
- 24 Cantilever bracket
- 26 Launched traveller
- 28 Raised formwork units for civil engineering
- 30 Balanced cantilever traveller and arch cantilever carriage

VARIOKIT for civil engineering

- 32 Heavy shoring tower
- 34 Load-optimised truss construction
- 36 RCS Rail Climbing System

VARIOKIT Engineering Construction Kit

System solutions for bridge, tunnel and civil engineering construction

PERI VARIOKIT, the engineering construction kit with rentable, standardized components.

The VARIOKIT system has been designed for the known load combinations of tunnel, bridge and building construction. With standardised, rentable PERI system components and construction-compliant connecting means, supporting structures can be cost-effectively erected and adapted geometrically to the respective structure.

High degree of versatility in the applications:

Bridges

- Launched Traveller
- Balanced Cantilever Traveller + Arch Cantilever Traveller
- Steel composite carriage
- Cantilever bracket
- Parapets
 - Parapet carriage
 - Parapet track
 - Parapet Brackets

Tunnels

- Cut-and-cover method
 - Monolithic
 - Semi-monolithic
 - Separate casting method
- Mining techniques
 - Semi-monolithic
 - Separate casting method

Civil engineering

- General civil construction
- Heavy-duty shoring
- Climbing technology

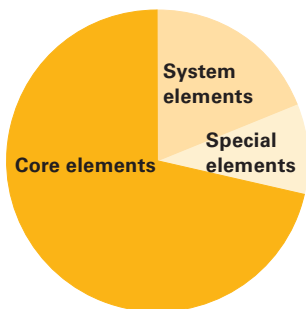

Steel Waler Universal SRU

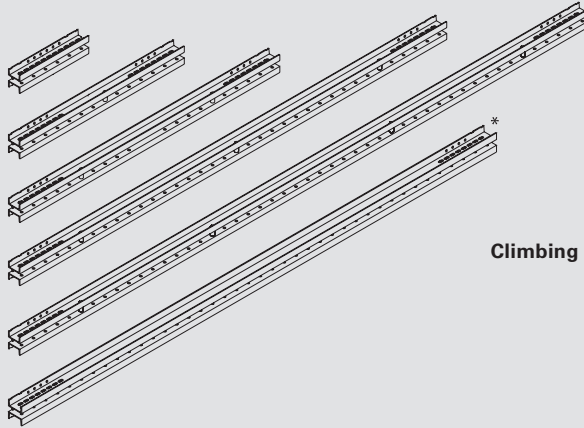

Climbing Rail RCS

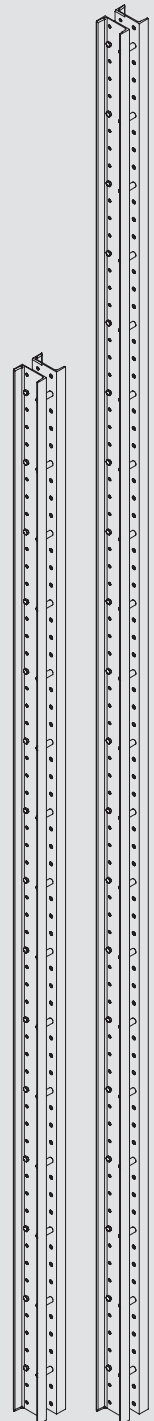

Heavy-Duty Spindle SLS

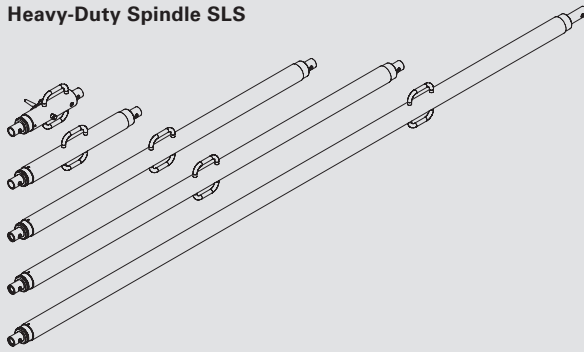

Only 3 basic components required for a wide range of applications.

- **Flexible**
Versatile core components with standard connections using bolts.
- **Load-optimised**
Cost-effective use of materials through the static utilisation of the components with project-related adaptations.
- **Rentable**
Economical solutions through the use of standard components taken from the PERI product range.

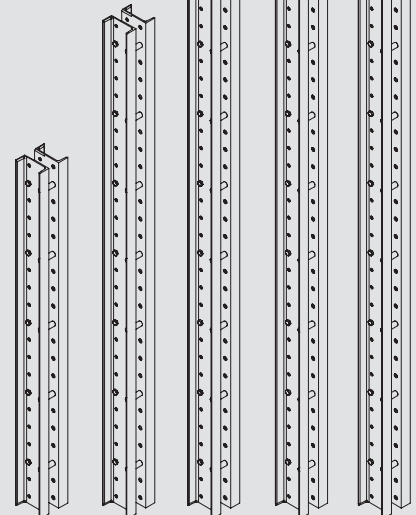

VARIOKIT for tunnel construction

Project-related designed tunnel formwork carriage consisting of standardised VARIOKIT components. Optionally available additional components such as drive mechanisms and hydraulic equipment for shuttering and striking increase the efficiency.



Project type
Cut-and-cover, separate casting method
Project
Bypass Tunnel, Tuttlingen, Germany

VARIOKIT for bridge construction

Flexible and cost-effective VARIOKIT formwork carriage solutions for bridge superstructures as well as construction of parapets, perfectly adapted to suit individual jobsite requirements.



Project type
Arch cantilever traveller and launched traveller
Project
Oparno Motorway Bridge, Czech Republic

VARIOKIT for civil engineering

The clearly defined permissible loads of the standardised components are suitable for all truss applications. Being able to rent the components along with the assembly advantages make VARIOKIT particularly cost-effective with short utilisation times.



Project type
General civil construction
Project
Avala TV Tower, Belgrade, Serbia

VARIOKIT Engineering Construction Kit

Engineering services and materials from one source

Engineering services and materials from one source

Engineering services

PERI not only supplies the required materials. Experienced engineers develop customised formwork solutions. They combine load optimisation, flexibility and functionality for a very wide range of construction site requirements.

Included in the PERI comprehensive solution is all technical documentation such as static calculations, assembly drawings and instructions for use as well as assembly support and continuous support throughout the project.

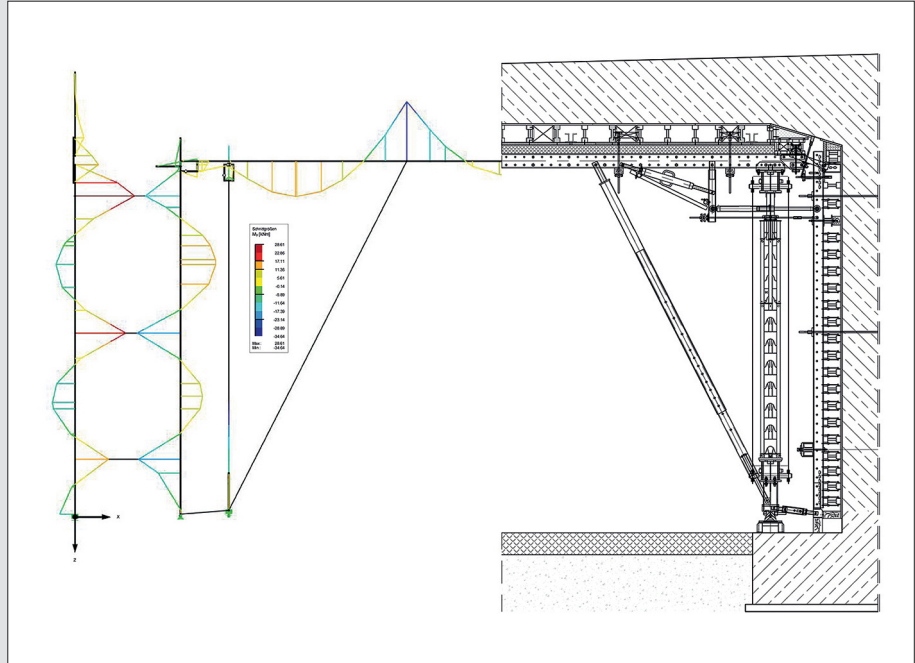

The planning of a tunnel with presentation of the moment curves in the system axes (left) as well as the cross-section (right).

The materials

VARIOKIT consists mainly of rentable standard components which remain unchanged but nevertheless are highly versatile in their use.

This results in the following benefits:

- small proportion of purchased parts.
- optimal adjustment to project requirements.
- as rentable system equipment at short notice from the rental park.



The three core components:

- Steel Waler SRU
- Climbing Rail RCS
- Heavy-Duty Spindle SLS

Each piece of formwork carries area loads (concrete pressure) via linear loads (waler loads) or individual loads (anchor or prop loads).

Classifying components in load groups allows load-optimized construction of the supporting formwork to take place over several steps.



Individual components and connections

Different components such as the Climbing Rail RCS and Heavy-Duty Spindle SLS, as well as the standard Ø 21 mm und Ø 26 mm bolt connections and their use, are type tested.

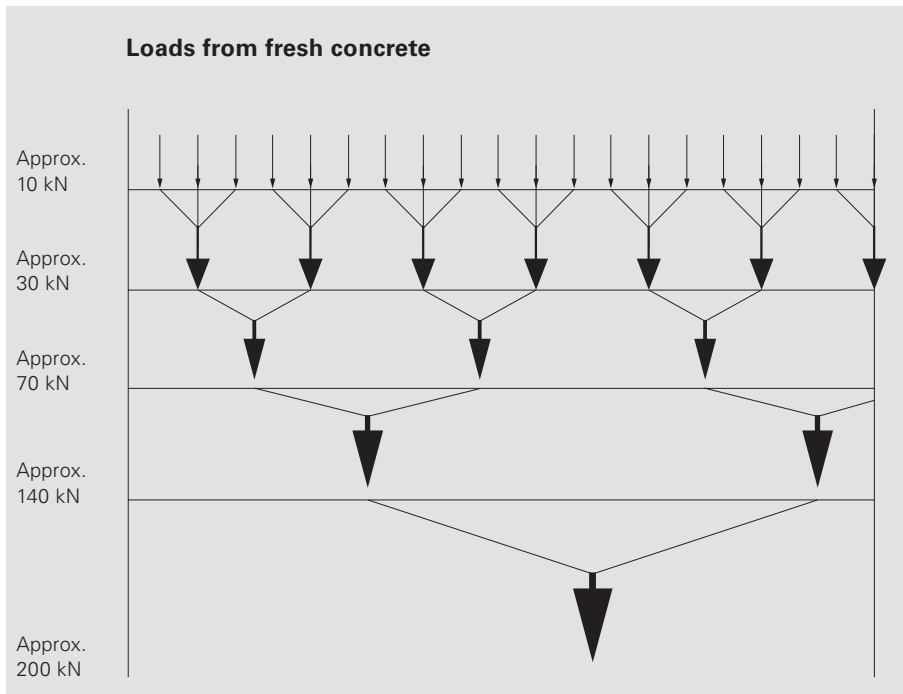

Perfect adjustment to the structure and load-optimized system solutions for cost-effective supporting formwork.

Further publications are available on tunnel and bridge construction:

PERI specialist literature

- Tunnel Formwork
- Bridge Formwork



VARIOKIT Engineering Construction Kit

Rentable standard system components

In cross-project situations standardized components are used again and again.

Components which have a mutual function are put together in groups. For example, the assembly group featuring the Heavy Duty Roller, Concrete Pump Connector or components for lifting, lowering or moving.

Fundamental details such as the scaffold tube connector as side protection are taken into consideration just as much as technical working requirements (e.g. Concrete Pump Connector). Also optimal additional components like the drive mechanism, electrical or hydraulic components are part of the wide range of possibilities provided by the PERI VARIOKIT.



As an option, the tunnel formwork carriage can be equipped with the hydraulic lifting and lowering unit. In addition, the unit allows easy adjustment of the formwork to suit the particular gradient.



RCS climbing rail with hydraulic climbing device.



Simple and effective, the scaffold tube connector on the guardrail post for optimal working safety.



The PERI BPA concrete pump connector is compatible to the TRIO, MAXIMO and VARIO GT 24 wall formwork systems.

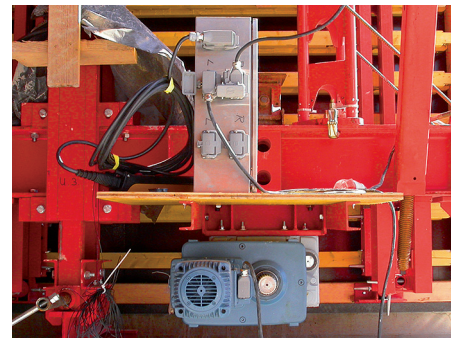

If required, the electric drive can be used for moving purposes. It can be retro-fitted on the wheel.

For the complete construction kit, there are only a few type connections with particular advantages:

- Very few different connecting parts, e.g. fitting pins and cotter pins.
- Standardized connection loads according to type of connection.
- Simple and easy on-site assembly.

With the Climbing Rail Connector RCS 97 Climbing Rails RCS can be extended without any loss of load-bearing capacity. In addition, Heavy-Duty Spindles SLS can be attached.

Heavy-Duty Spindles SLS are mounted to the RCS Climbing Rails by means of Spindle Adapters SLS/RCS.

The Scaffold Tube Adapter RCS Ø 48 connects scaffold tubes Ø 48 mm with the load carrying system.

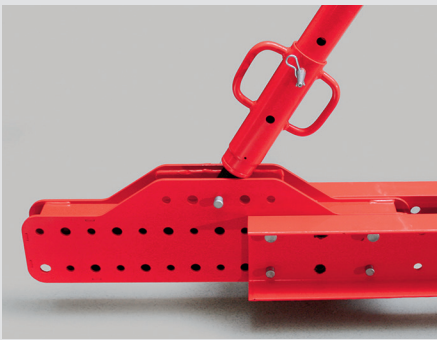

Climbing Rail Connector RCS 97
Item no. 111390



Spindle Adapter SLS/RCS
Item no. 110477

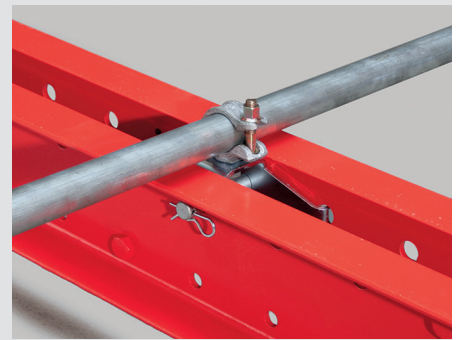

Scaffold Tube Adapter RCS Ø 48
Item no. 110084

For using the RCS climbing rail as waling for wall formwork, the GT 24 is mounted with the Hook Strap Uni HBU 24-26 U 200.

Frame structures and brackets are constructed with the Climbing Rail Angle Connector RCS. Connecting the SLS heavy-duty spindles or tie yoke can also easily be carried out.

The Angle Connector RCS/SRU can be installed both as an articulated as well as rigid connection.



Hook Strap Uni HBU 24-26 U200
Item no. 111806

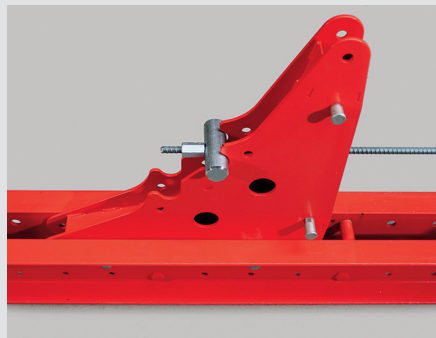

Climbing Rail Angle Connector RCS
Item no. 111382

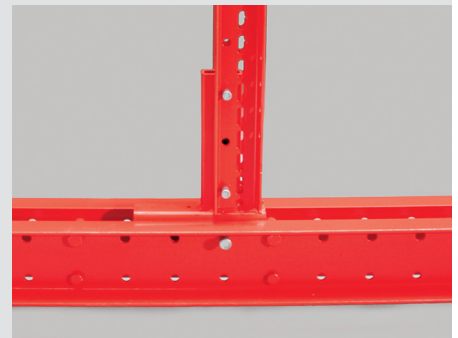

Angle Connector RCS/SRU
Item no. 111283

VARIOKIT for tunnel construction

Cut-and-cover, semi-monolithic construction method

Tunnel formwork carriages are always project-related solutions. VARIOKIT provides an answer with standardized system components.

The advantages of the PERI VARIOKIT formwork carriage:

- Few anchors required in wall areas due to system walers up to UU 200.
- Easy modification to suit different cross-sections.
- Hydraulic assistance for erecting and striking formwork as well as for raising and lowering is optionally available.
- Self-propelled or mobile solutions for moving complete units.



All components can be optimally adapted:

- The HD 200 heavy-duty props allow continuous height adjustment and gridless assembly versions.
- The RCS slab beam can be flexibly adapted.
- The VARIOKIT diagonal strut is continuously usable from 4.0 to 9.0 m.

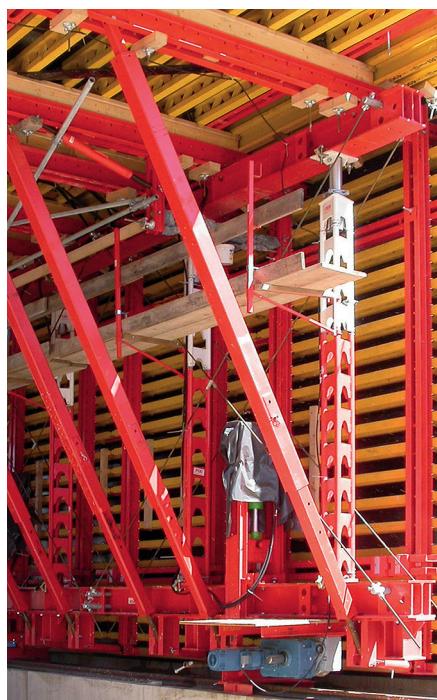

The diagonal strut is mounted on the slab beam with standard connections. The regular hole pattern in all system components provides many connecting possibilities.



The combination of proven systems such as VARIO GT 24 and HD 200 with new elements from RCS or the diagonal strut, results in a cost-effective formwork carriage.



The modular PERI VARIOKIT system for a wide range of practical solutions.

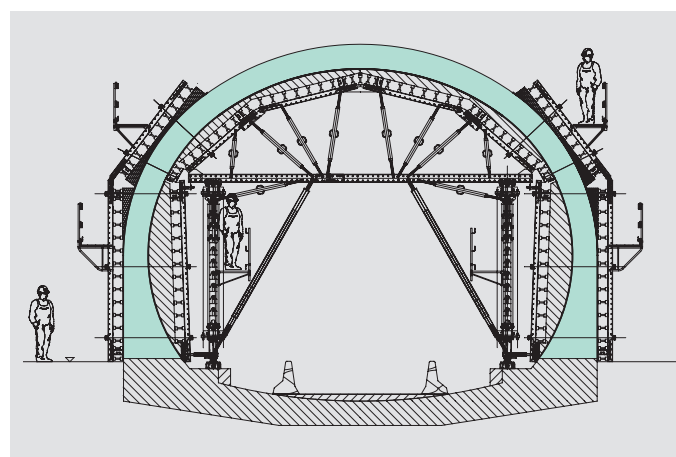

Circular cross-sections are just as possible as separate individual formwork carriages for walls and slabs.

VARIOKIT for tunnel construction

Cut-and-cover, separate casting method

The separate casting method is the simplest variant for the construction of tunnels using the cut-and-cover modus operandi.

Here, the advantages of the VARIOKIT construction kit really come into their own. Through the possibility of being able to rent the system, a mobile transporting unit pays off also if only a few cycles are required.

Economical formwork solutions as well as tunnel cross-sections with variable dimensions are the standard applications of the separate casting method. All PERI wall and slab formwork systems can be used here.

Mobile solutions are normally realised with VARIOKIT components.

■ Technical processing

Well-engineered technical planning allows cost-effective and efficient solutions which are precisely tailored to meet the requirements of the construction site. Regardless whether it is access portals for trucks or single-sided wall formwork with overhead support, such solutions are problem-free with VARIOKIT.

■ Wall Formwork

The wall formwork is comprised of components such as waling, girders, accessories and anchoring systems which are available in the PERI VARIOKIT standard programme. At the same time, it offers considerable design possibilities and can also be constructed to handle high concrete pressures. This allows fast concreting with high form stability.

■ Minimum of anchors

The number of anchors can be clearly reduced through the use of the DW 20 and 26 tie systems which results in a substantial cost benefit.

■ Slab Formwork

A project-related slab formwork carriage usually consists of one VARIOKIT load-carrying system and the formwork level. VARIO GT 24 girder wall formwork is frequently used for the formwork level.

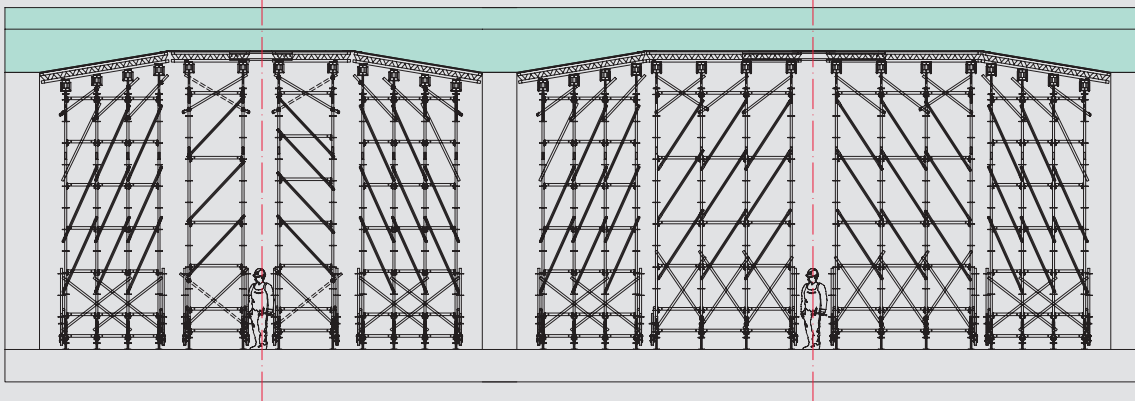



Clearly visible are the 2 separate concreting cycles, the wall on the left and the slab on the right. Both sets of formwork are designed as mobile units.

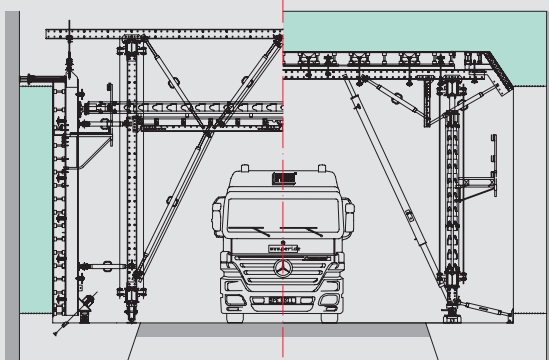

VARIOKIT for tunnel construction

Mining, semi-monolithic construction method



As a general rule, a formwork carriage for mining tunnels must fulfil very high requirements regarding wet concrete pressure and dimensional accuracy.

With shorter tunnels (up to approx. 40 sections) as well as for widened areas etc., formwork carriages which have been assembled using rentable system components are used.

It is particularly with the use of these standard components that the advantages are clearly demonstrated through the short operating times or very few sections. Rentable components also for high loads, hydraulic control elements and electric drive units, make the standard carriage very easy to use. In addition, the time required for assembly and dismantling as well as moving are about the same with both versions.

Technically demanding solutions and easy handling are not mutually exclusive. As a result, constructions can be realised with VARIOKIT which optimally fulfil the boundary conditions of the construction site.

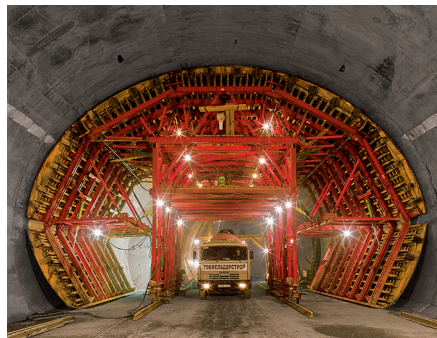

For mining tunnels, access portals are an important prerequisite for the use.



The PERI UP scaffold system offers all possibilities - from a simple stair tower through to a complete sealing carriage.

- High permissible concrete pressure**
 Mining tunnel formwork carriage safely accommodate wet concrete pressures of up to 120 kN/m².

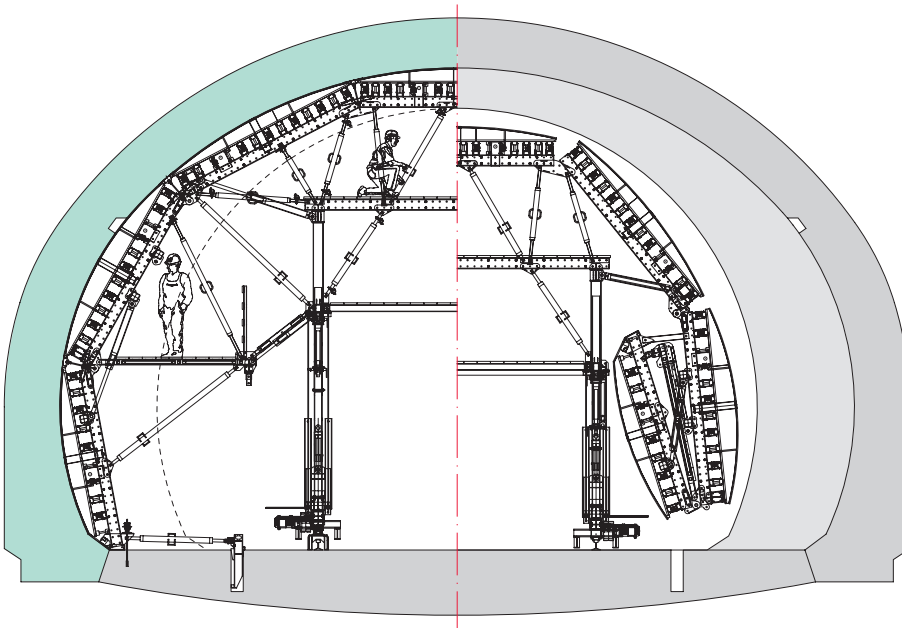

This tunnel formwork carriage can fold itself to suit the passage dimension of the standard cross-section, move laterally along the correct axis (with the help of the lifting and lowering unit) and subsequently move forward. After this, it is moved sideways again and brought into the concreting position.



Optional VARIOKIT accessories such as hydraulic winches, electric drive units, lifting and lowering



units and hydraulic cylinders for operating the wall and slab formwork elements are available in



the VARIOKIT construction kit and, if necessary, are planned according to project requirements.

VARIOKIT for tunnel construction

Mining, separate casting method

The extremely high loads carried by a tunnel formwork carriage during mining operations present a special challenge for PERI VARIOKIT.

In order to effectively manage the forces and, at the same time, provide construction site traffic an access portal, the VARIOKIT with anchoring components combination is supplemented with the SB brace frame system. For smaller tunnel lengths (< 40 cycles) with short section lengths (< 20 m) and tight construction schedules (< 12 months), solutions using rentable parts are considerably more cost-effective than complete project solutions with special steel components.

For tunnels constructed using mining techniques, the formwork is always designed whilst considering ancillary conditions which are, in part, not compatible:

- large loads resulting from the fresh concrete pressure and dead weight.
- low individual weights due to tight space conditions during assembly and operations.
- minimum of material costs from high proportion of rental parts and small quantities.
- few operating elements and optimally adapted to suit construction progress.
- simple operation of large units.



The first section with the bottom slab and starter has already been concreted.



Best concrete results from the 2nd cycle (wall area) form the exit for the arched formwork carriage.



The experience gained from brace frame anchoring can also be used in the 2nd cycle.



System components for the carriage and the movable formwork suspension allow flexible utilization.

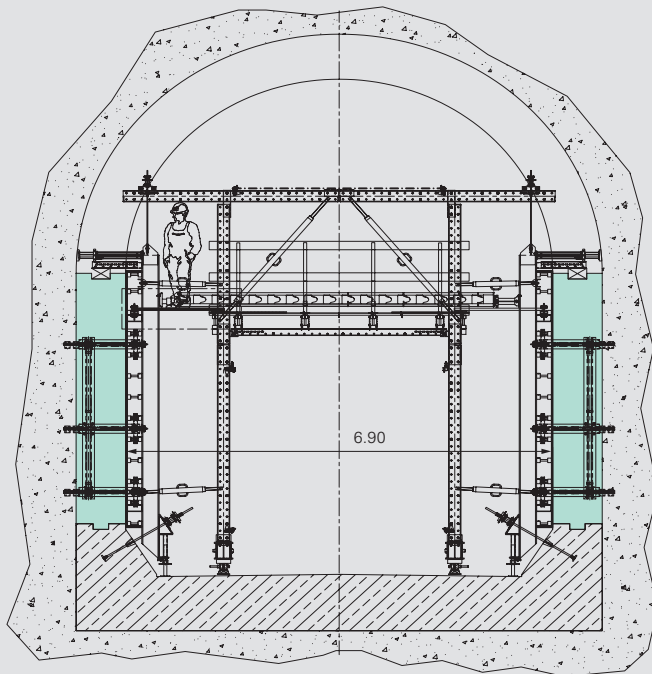

The transportation carriage from the RCS system moves the formwork and support unit to the next cycle.

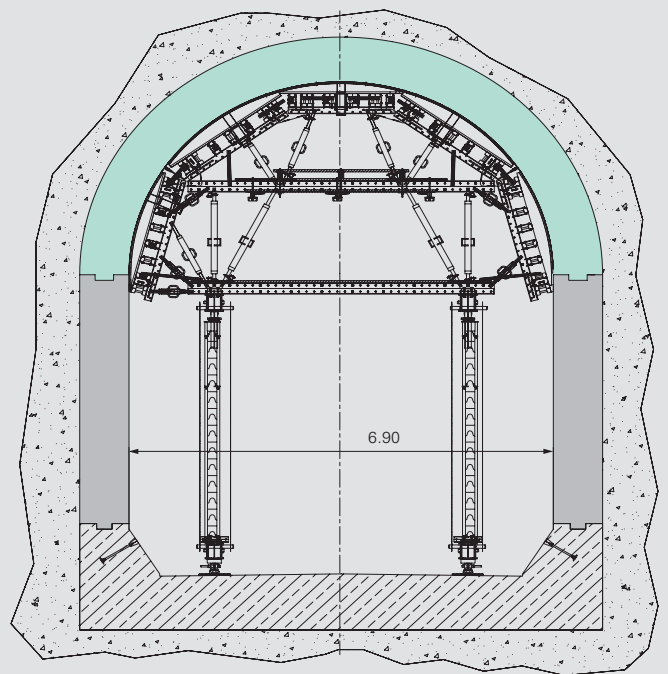

The formwork carriage for the 3rd cycle (arched section) also corresponds to project requirements.

Through the possibility of installing only those parts in the component levels which are required in each case for transferring in part large forces, load optimization can be achieved.

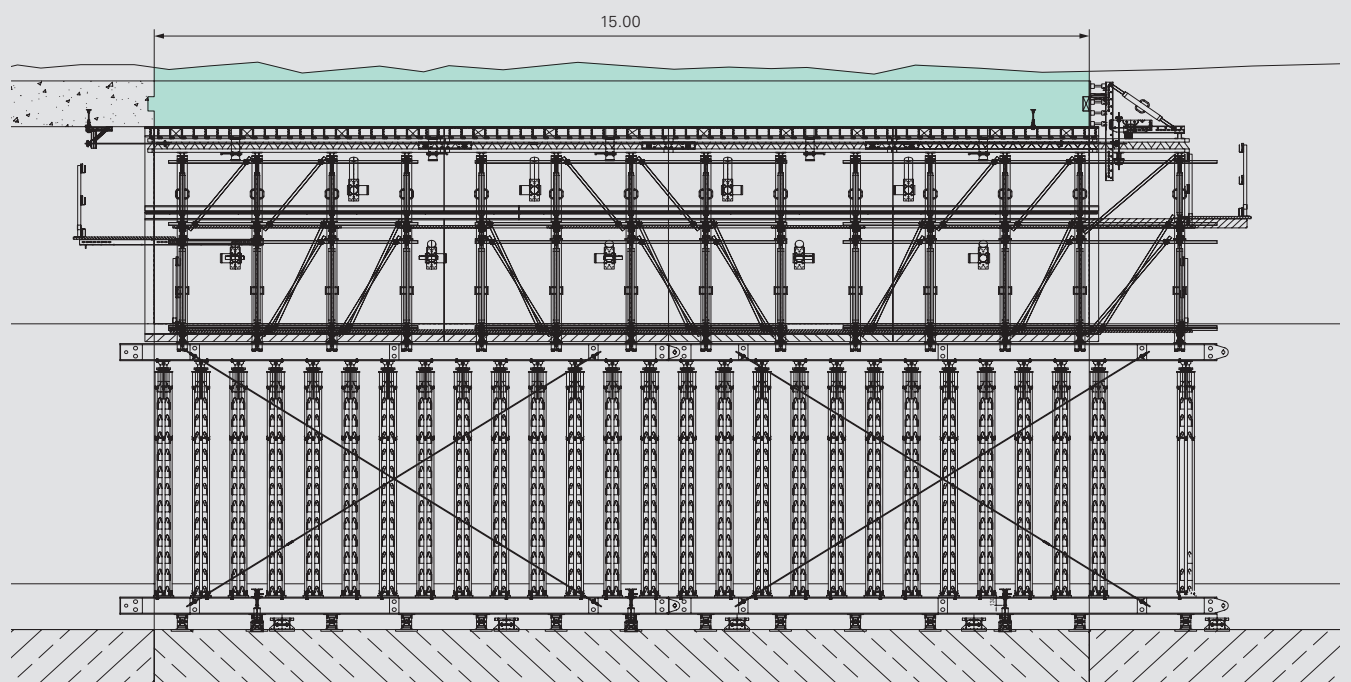

VARIOKIT for bridge construction

Parapet track



The VARIOKIT parapet track is used for the construction and refurbishment of parapets at the edge of bridges and between the superstructures.

Their main components are:

- multifunctional rails
- roller unit
- Anchorage

The interaction of these 3 parts leads to the fact that load cases such as moving, vertical and horizontal concrete loads and the dead weight are likewise transferred like loads from working operations and wind without any additional fixings to the superstructure. Through the anchoring to the underside of the bridge and the low structural height, the parapet to be formed is freely accessible. Working operations can be carried out on and under the bridge during moving traffic.

Through the flexible adaptation of the parapet track, outer and middle parapets can be realised without any problems.



Free access from the top side of the bridge without disruptions through the overhead load-carrying construction.



Optimal and flexible adjustment to the bridge geometry for the construction of the middle parapet.

GS-certified safety for the GKB work cage.



The geometry of the suspension anchor allows fast lateral and perpendicular self-adjustments of the roller unit.



The track units roll self-centering over the roller units and rails along the bridge gradient.



Assembly on the bridge superstructure takes place with the GKB work cage while the assembly fitter is secured by means of personal protective equipment against falling.

Striking procedure

The parapet track is moved as a complete unit. The rollers to be freed up are dismantled from the finishing platform and re-mounted in the moving direction at the front from the leading platform.

In accordance with the size of the parapet, anchor spacings of 100, 125 and 150 cm can be

realised by combining the 100 and 150 cm rail lengths. This leads to optimal utilisation of the formwork carriage and a reduction in the number of anchor points.

Safe access possibilities to the platforms are provided via the leading and finishing platforms.

Cross-section

Safety during concreting and operations is guaranteed at all times through separate concreting and working platforms.

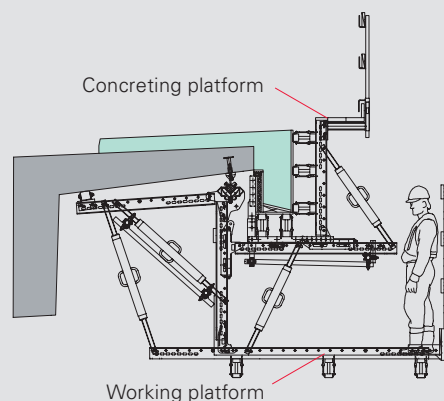
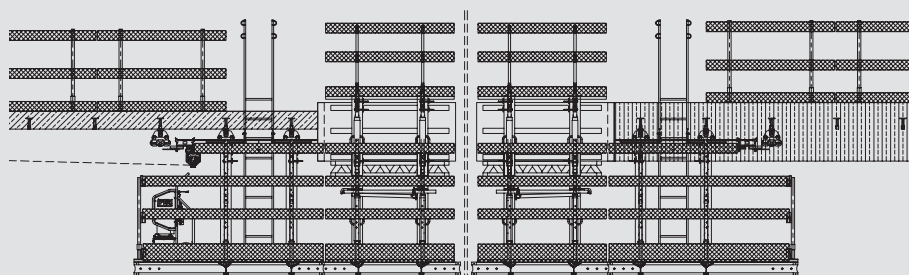

VARIOKIT for bridge construction

Parapet carriage



For meeting the requirements of modern bridge construction, the PERI parapet carriage provides an economical and efficient solution.

Thanks to the VARIOKIT construction kit, it can be optimally adapted to the construction site requirements.

The advantages of the VARIOKIT parapet carriage:

- less deformations under load.
- variable spacings between the individual sections.

Moving the formwork carriage is carried out cost-effectively and according to project requirements by means of steel profiles. As a rule, no anchorage is required for the structure and the horizontal force is transferred with friction.

The few different components actually required can be clearly seen here:

- SRU steel walers
- RCS climbing rails
- Heavy-Duty Spindles SLS
- accessories such as scaffold tubes and couplers

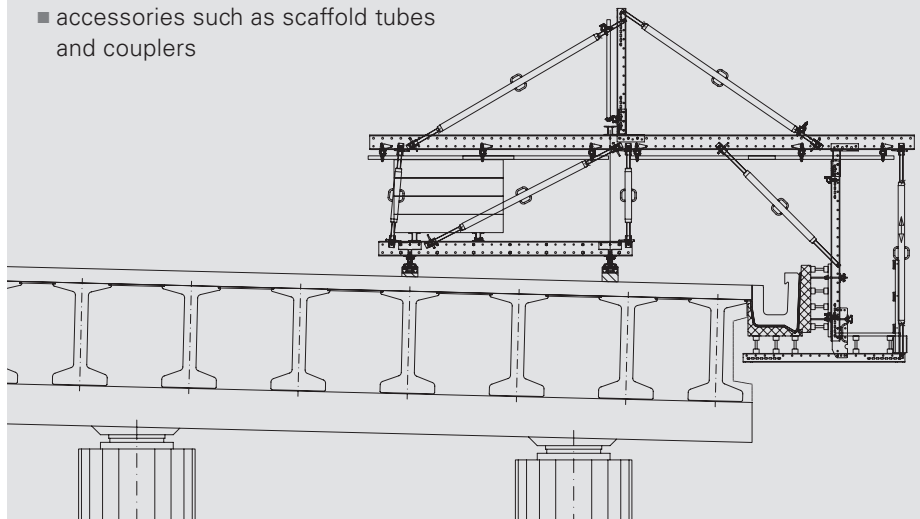

All required adjustment works take place from the working platform. At the same time, there is an option of using a second working platform.

The different versions can be adapted to the structure and allow:

- keeping the clearance profile free
- construction of special geometries
- working areas for inspection work on the structure's web.



Projects with special requirements such as this bridge show the high degree of variability of the PERI VARIOKIT parapet carriage. Here, 5.00 m had to be spanned without support on the pedestrian and cycle lanes.

Short cantilever overhangs, interruptions through transversal steel girders in the area of the cantilever and limited clearance profiles are the decision criteria for the PERI VARIOKIT parapet carriage.



VARIOKIT for bridge construction

Parapet bracket



The lightweight PERI parapet bracket can be installed by hand and rounds off the range of parapet solutions. For the new construction of short bridge superstructures as well as refurbishment, the parapet bracket is a rational and economical solution.

Special attention during the development was focused on the weight reduction of individual components. The heaviest part weighs only 18 kg and thus allows assembly by hand.

Apart from the weight reduction, particular importance was placed on completely separating the formwork support from the platform. Due to this separation, closed enclosures through to watertight enclosures can be realised.

Adjusting to the parapet geometry and operations safely takes place from the closed platform.

For the construction crew this means:

After the initial assembly, access by means of an elevating work platform or scaffolding is not necessary.



Due to separating the formwork support and platform, re-installation of the platform after the demolition work for concreting is not required. The formwork support is simply positioned on the platform.

The VGK parapet bracket platform unit for the demolition of a parapet.

The mounting shoe of the bracket allows 2 versions of anchoring:

- New bridge construction with the high load-bearing and proven PERI Anchor Sleeve M24.
- Bridge refurbishment with various commercially available bonded tie systems together with official approval.

Easy and fast assembly by hand.



The bracket suspension head with anchoring details.

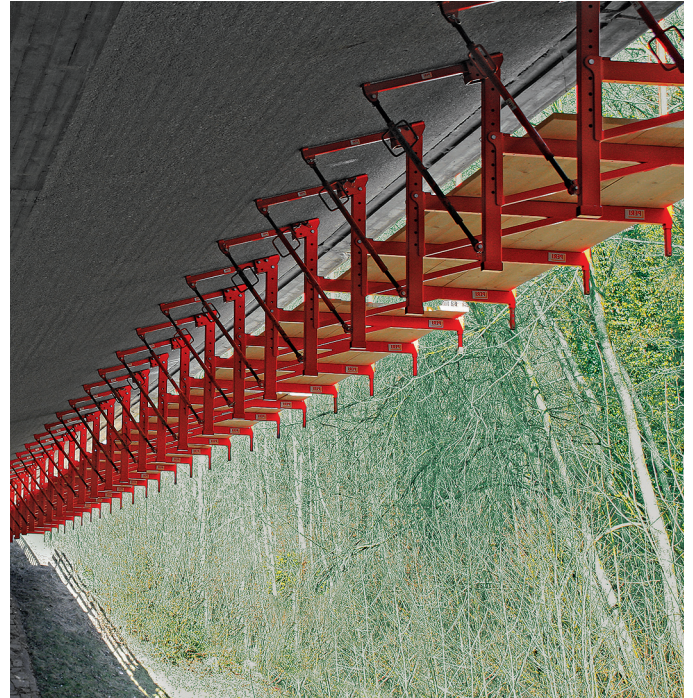
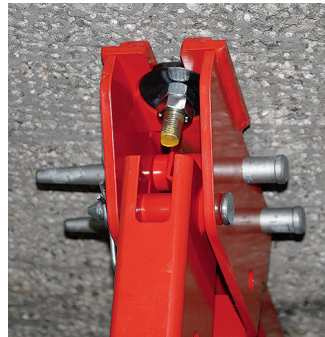

The VGK parapet bracket has been designed for horizontal and vertical use. The consoles can be mounted to the underside of the cantilever as well as the abutment walls by simply re-bolting.

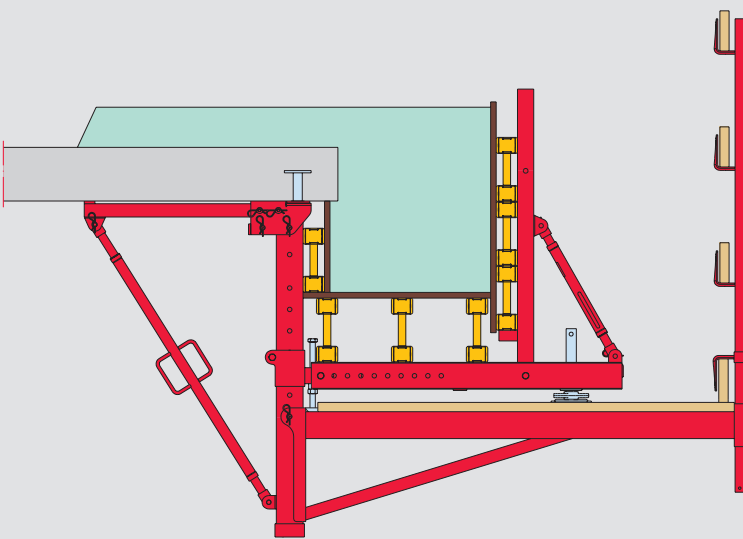

Horizontal use
in the area of the cantilever.

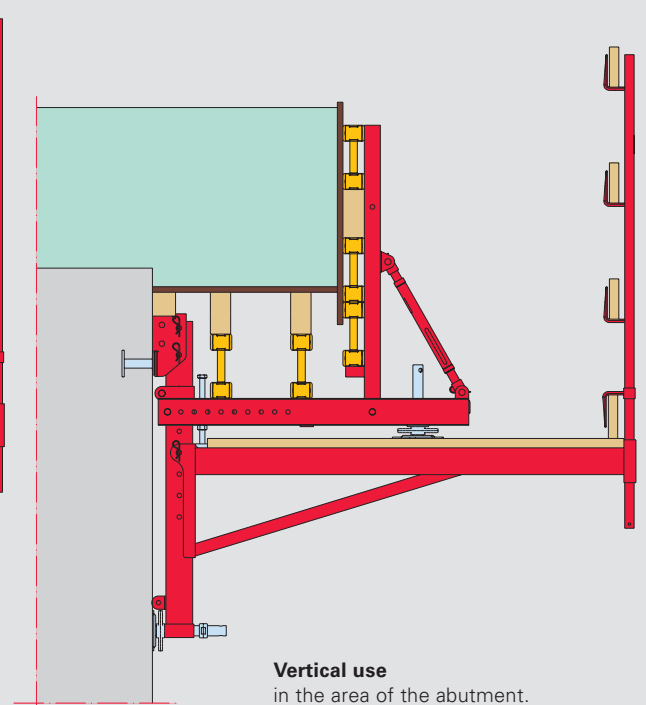

Vertical use
in the area of the abutment.

VARIOKIT for bridge construction

Steel composite carriage

The VARIOKIT formwork carriage for steel composite bridges fulfils all the project requirements.

The advantages of the PERI VARIOKIT formwork carriage:

- high rigidity in both the longitudinal and transverse directions of the carriage.
- variable and flexible arrangement of the support points (carriage supporting point) on the bridge longitudinal beam.
- with the unique steerable carriage supporting shoe (with heavy-duty roller), forming of bridge radii is possible without any great effort.
- through the rigid longitudinal truss, cross frames are not restricted by any increments and can always be completely utilized.

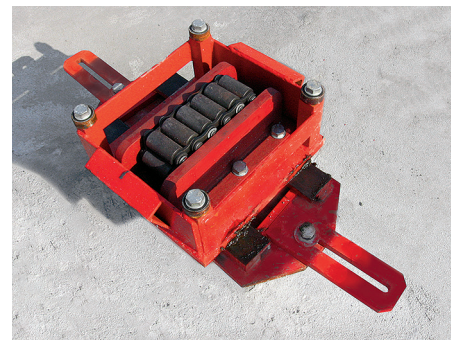

The extremely rigid main beam truss ensures optimal load distribution and protects the bridge girders against excess point loads.

The steerable carriage supporting shoe is mounted to the carriage supporting point.

Striking can take place either from the concreting level or the finishing platform.



The internal formwork is selected according to the geometry of the structure.

In so doing, a difference is made between:

- movable slab formwork element on roller brackets
- MULTIFLEX formwork
- panel formwork

Through the enormously high number of combination possibilities for the system components, modifications can also be carried out at any time for other bridge cross-sections.

The external formwork carriage is mounted to the main beams of the bridge. The three main component groups can be clearly seen:

- longitudinal truss
- cross beam
- formwork unit with adjustment device

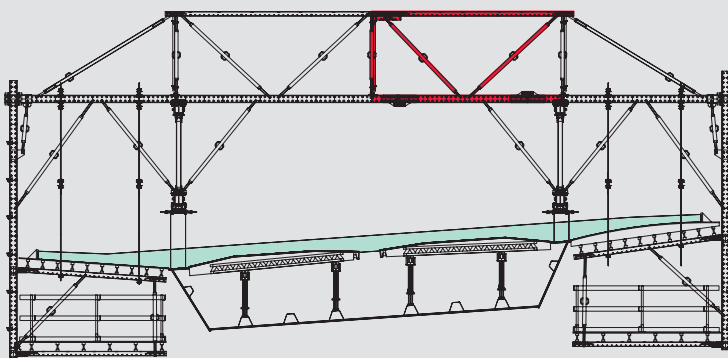

Project 1
Internal formwork with MULTIFLEX

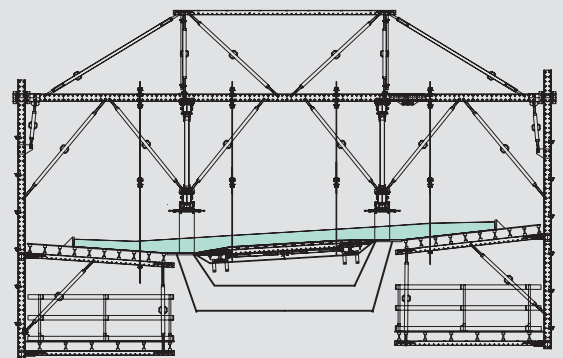

Project 2
Internal formwork as movable slab formwork element on roller brackets

Modifying the formwork carriage is a simple process by extending the components marked in red.

VARIOKIT for bridge construction

Cantilever bracket

The PERI VARIOKIT cantilever bracket is the construction kit solution for the realisation of bridge cantilevers using the steel composite and semi-prefabricated concrete component construction methods.

Both for short crossings of railway lines, motorways or side streets as well as with large formwork quantities, the cantilever bracket provides cost-effective and rational solutions.

The necessity for a mobile solution does not apply with these projects as the superstructure is usually constructed in one casting segment.

Decisive advantages:

- fast assembly
- low dead weight
- suspension with DW 15 system

Bridge near St. Paul, Austria:
railway crossing.



Areas of application for the VARIOKIT cantilever bracket are:

■ Steel composite construction method

Combination of steel girders in the tensile areas and in-situ concrete slabs in the compression areas of the bridge cross-section.

■ Semi-prefabricated concrete component construction method

Tensile area of the prefabricated concrete girders and compression areas from the in-situ concrete slabs.



Steel composite construction method

Chinchage Brücke, Canada
Steel girders with in-situ concrete slabs.



Semi-prefabricated concrete component construction method

Golden Ears Bridge, Canada
Prefabricated concrete girders with in-situ concrete slabs.



Bracing the bracket units with commercially available scaffold tubes Ø 48 mm.



The bracket units with side protection mounted on the steel girders serve, at the same time, as guardrails.

For anchoring, the DW 15 tie system comes in two versions.

Fixing to the steel girders is carried out by means of the weldable and screwable VARIOKIT anchor plate.

■ **Operable from the top side of the bridge**

The assembly and dismantling of the brackets takes place from the top side of the bridge via re-usable conical pipe nuts.

Advantages:

- No elevating work platform or ground-supported erection scaffolding is necessary.

■ **Operable from the underside of the bridge**

The bracket is fixed from below via the Tie Yoke Head SRU.

Advantages:

- no penetration of the superstructure.
- no interruption points in the concreting work.



Support spindles for optimal adjustment to the bridge cross-section with an adjustment range of +/- 10 cm.

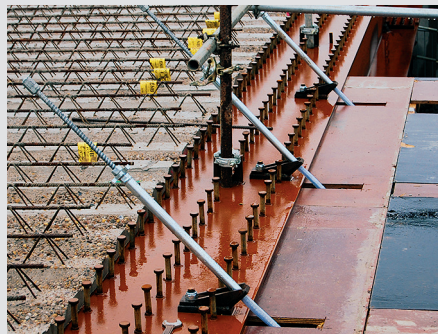

Anchor plate with pipe nut and DW 15 tie rod, can be operated from the top side of the bridge.

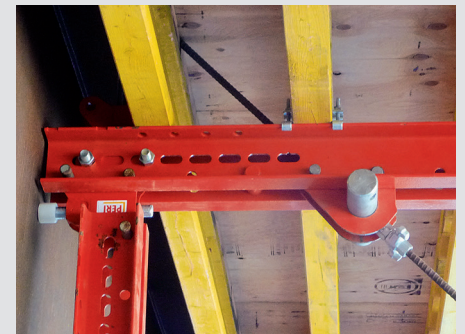

Tie Yoke Head SRU with DW 15 tie rod, can be operated from the underside of the bridge.

VARIOKIT for bridge construction

Launched traveller

The PERI VARIOKIT solution for the building method with underslung and overhead launched travellers.

In the process, the solution overhead launched traveller has a main beam on which the crosswise arranged trusses are positioned which carry the concreting loads of the cantilever. With suspension tie rods on the outer frame, all adjusting possibilities regarding inclination and position are possible.

■ Hydraulic operations

For some VARIOKIT projects, there is the option of being able to operate the formwork components with a mobile hydraulic system which is also available for use with the above-positioned launched traveller. Thus, only 4 hydraulic lifting cylinders are required regardless of the number of raised formwork units.



■ Assembly versions

The construction for both launched traveller versions – positioned overhead and underslung – is a modular design. Load-optimised width of influence on the two cross-frames form the basis of each launched traveller. The total number of cross-frames is, in each case, a multiple of the pairs of frames.



The transfer of the bearing loads into the pier is a very important area. Adaptable to the structural geometry and with system safety accessories, PERI UP provides an optimal solution here.



Assembly of the sub-assemblies in a position behind the abutment is the rule regarding initial assembly. At the same time, passing the abutment wall is a factor that must be taken into consideration.



Moving past the piers is possible without any problems after the working platform and slab formwork have been hydraulically folded in.



The underslung launched traveller can also be supplemented with system formwork thus ensuring cost-effective use. For moving, the traveller and formwork are firstly pushed sideways, then moved forward in a longitudinal direction and subsequently realigned.

VARIOKIT for bridge construction

Raised formwork units for civil engineering



PERI VARIOKIT raised formwork units provide flexible and economical solutions for a very wide range of requirements in modern civil engineering projects.

Due to their high flexibility, the units can be mounted on different load-bearing systems. Thus, the same raised formwork units are used on launched travellers, incremental launching equipment as well as light to heavy load-bearing scaffold.

Adapting to the wide range of bridge geometries take place continuously thanks to the VARIOKIT engineering construction kit.



Raised formwork units on the launching beam with large spans.

Raised formwork units on PERI UP Rosett supporting scaffold.



Frame construction formwork for incremental launching equipment. The raised formwork units remain firmly positioned on one side of the abutment and serve as formwork for the cyclic construction of the superstructure.

Time-saving and cost-efficient construction site assembly can be realized due to standardized connecting components such as the UK 70 coupling and bolt connections.

The formwork can be adapted at any time to structural changes by means of SLS spindles. Through this, VARIOKIT frame construction formwork provides a very flexible and economical solution for all conventional load-bearing systems and a broad range of building geometries.



Main components of the raised formwork units:

- Steel Waler SRU 120
- SLS Spindles
- Coupling Components
- Bolts Ø 21 or 26 mm



■ Articulated connection
For transferring normal and shear forces between two walers. This results in a fully adequate joint between the SRU steel walers.

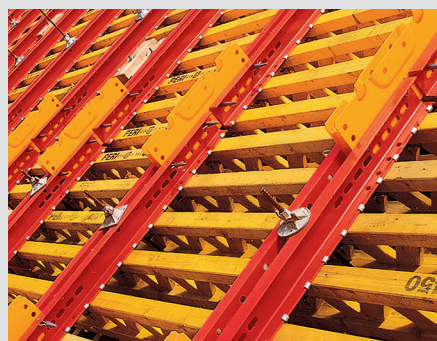

■ Rigid connection
All waler lengths can be combined without any loss of load-bearing capacity. The static values of the UK 70 coupling correspond to the profile of the SRU waler. The connection with the bolt Ø 21 x 120 mm is without any clearance.



■ Connecting accessories
In the widened areas, accessories can be bolted on. This means that spindles and diagonals etc. can be optimally positioned at the required points without having to take the couplings into consideration.

VARIOKIT for bridge construction

Balanced cantilever traveller and arch cantilever carriage

The PERI VARIOKIT solution for arch cantilever traveller is a combination of hollow box girders for carrying the loads and VARIOKIT standard components for the formation of formwork, working scaffold and platforms.

A self-launching procedure by means of integrated moving hydraulics, complete hydraulic adjustment and alignment lead to accurate concrete results. Millimetre deviations can be realized with arched spans of up to 140 m.

■ Time-consuming technical planning

Balanced cantilever equipment and formwork normally experience large changes in geometry and load which result from the varying heights of the superstructure towards the middle span. Here, detailed technical planning is indispensable. In addition, the constantly changing load conditions along with the resulting loads and deformations must be accurately calculated.

Using the very latest 3D formwork planning, PERI provides perfect implementation plans and detailed processing which make on-site forming cost-effective and efficient.



Changes to the external geometry of the web require variable constructions. VARIOKIT steel walers and spindles provide here a continuous and safe load-carrying system.



The PERI VARIOKIT balanced cantilever traveller consists of new main frames which allow compensation of the bridge longitudinal and lateral inclinations to be carried out without packing timber.

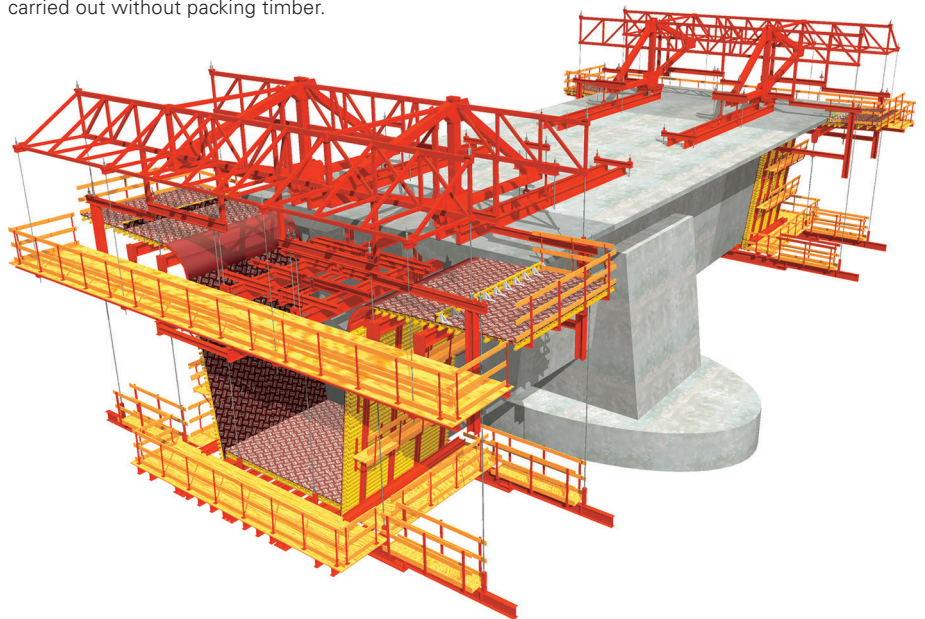

Furthermore, the inner sides of the bridge web also require filler areas in both the width and height. The VARIOKIT adjustment unit offers continuous adjusting possibilities.



Geometrically complicated details in the cantilever area can be flexibly formed with the VARIOKIT construction kit. Moving the formwork takes place by means of a lightweight chain hoist.



The transfer of the loads into the pier is a very important area. With the PERI UP scaffold system, flexible and safe access to this area is realised.

VARIOKIT for civil engineering

Heavy shoring tower



Heavy-duty shoring has been in use for many years in civil engineering. As the first manufacturer, PERI has redefined the application in the course of developing the VARIOKIT engineering construction kit.

With this, the disadvantages of the two conventional versions, load-bearing scaffold with steel profiles and special scaffold tower systems are avoided without additional application. Technical processing of heavy-duty shoring applications is very challenging. PERI makes this possible using the latest technology and flexibly used system parts. Here, the advantages of a large range of components come to the fore. Always having the correct length facilitates a cost-effective planning process. Heights to 40 m can be realised with VARIOKIT heavy shoring towers with a constant high load-bearing capacity up to max. 240 t.

4 assembly types are possible:

■ **Standard tower**

4 legs are assembled using the standard connection parts. This results in an axial dimension of 2 x 2 m.

■ **Tower with additional legs**

In very highly-loaded areas, additional legs can be placed with leg spacings of 37.5 cm. With this, the permissible load-bearing capacity is then doubled.

■ **Shoring tower frames**

Is a combination of legs to "frames" with load-dependent and geometrical necessary number of load-carrying components.

■ **Assembly as main beam frame**

Main beam frames, e.g. in front of abutment walls, can be assembled up to 10 m high as independent units only with head restraint.



A typical application example in bridge construction. VARIOKIT heavy shoring tower with heights from approx. 5.00 m up to 40.00 m.

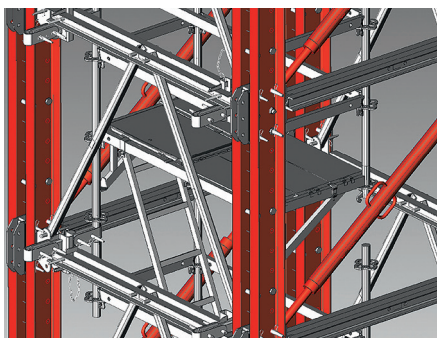

With PERI UP scaffold construction kit, all required stairs, access points and working platforms are quickly and safely erected.



The Leg Connector VST 48 is equipped with a centering aid. This allows easy and simple extensions.



With PERI bolts, the main connections of the individual components are carried out quickly, accurately and safely.



One component for extensions and base units – the Leg Base VST 48.

VARIOKIT for civil engineering

Load-optimised truss construction

With the help of VARIOKIT engineering construction kit, flexible, load-optimised and versatile trusses can be designed for load transfer.

Depending on the load, SRU Waler 120, RCS Rails U 200 or HDT Main Beam HEB 300 serve as the chord of the truss; in combination with SLS Spindles or rectangular struts as diagonal bracing, load-optimized solutions can be designed.

The extremely variable adjustment to the structural geometry takes place by means of a defined set of holes with 12.5 cm increments in the SRU and RCS rails.



Same system components for providing temporary support for the structure as well as for climbing scaffold application.



Adaptable trusses for transferring fresh concrete loads and as temporary structure support.



Simple and fast construction site assembly by means of bolted connections.

Main connecting means are bolts and fitting pins with Ø 21, 26 and 40 mm. Jobsite assembly is accelerated through standardized connecting components such as the UK 70 coupling or RCS 97 climbing rail connector.

Creation of horizontal assembly areas on inclined roof areas for falsework with VARIOKIT components.



The VARIOKIT system construction kit provides numerous combination possibilities with other PERI system components.



Rentable solution in bridge construction. Truss comprised of SRU steel walers with SLS spindles as diagonal bracing.

VARIOKIT for civil engineering

RCS Rail Climbing System

The RCS climbing system combines the advantages of different climbing systems in one modular system.

Depending on the requirements and use, the system can be climbed with the crane, or raised crane-independently by means of mobile, hydraulic climbing devices. The RCS modular construction kit allows standard solutions to be easily adapted to project-specific requirements.

■ RCS climbing protection panel

For completely enclosing floors under construction particularly those in high skeleton structures.

■ RCS Formwork Scaffolding

For rail-guided climbing of wall formwork.

The flexible anchoring of the RCS climbing system is the basis for numerous project successes all around the world, also for many extraordinary structures.

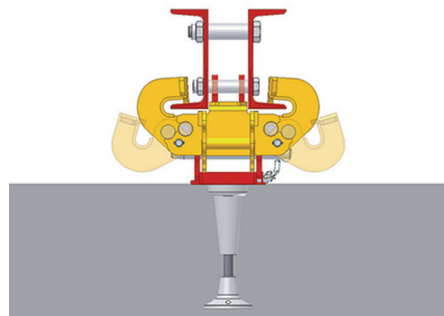

The RCS climbing shoe guides the climbing rail during the moving procedure. The integrated climbing pawl automatically engages the connection bolts of the climbing rail and secures the unit at a distance of 50 cm. Already during the first concreting cycle, the upper part of the formwork scaffolding is attached to the foldable runners of the climbing shoe.



Formwork for cores or facades of a high-rise building is climbed with PERI RCS just as safely and cost-effectively as for bridge piers.



Section of a RCS climbing protection panel

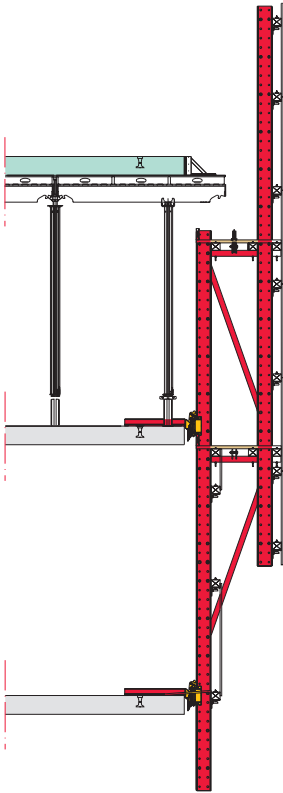

Section of RCS formwork scaffolding

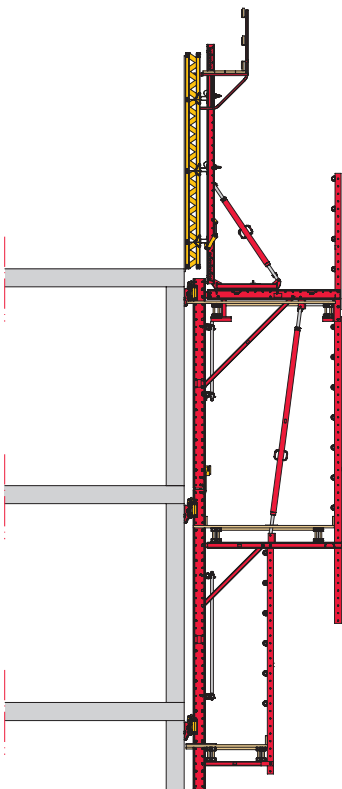

Both systems can also be climbed hydraulically and therefore are crane-independent.

With the mobile self-climbing devices and hydraulic pumps, the cost of the self-climbing equipment is reduced as well as ensuring cost-effective implementation for structures with lower height.

Hydraulic pumps and cylinders are quickly operational and easy to transport.

With the climbing rail, the scaffold unit is always connected to the building by means of the climbing shoe for the entire climbing procedure. Moreover, it is impossible for the RCS climbing unit to "drift" during strong winds. This means that climbing can take place safely and quickly at any time.

The hydraulic cylinder, with 5 t lifting capacity, can be easily positioned on the climbing shoe and rail.

Advantages:

- The climbing rail is not climbed in advance but, instead, is part of the load-bearing system.
- Wall openings are easily bridged by the climbing rail.
- The mobile self-climbing equipment can be retrofitted at any time.

Climbing units are raised with a lifting speed of 1 m/min.

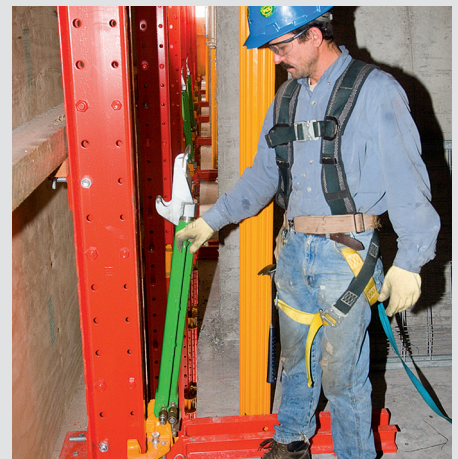

PERI International

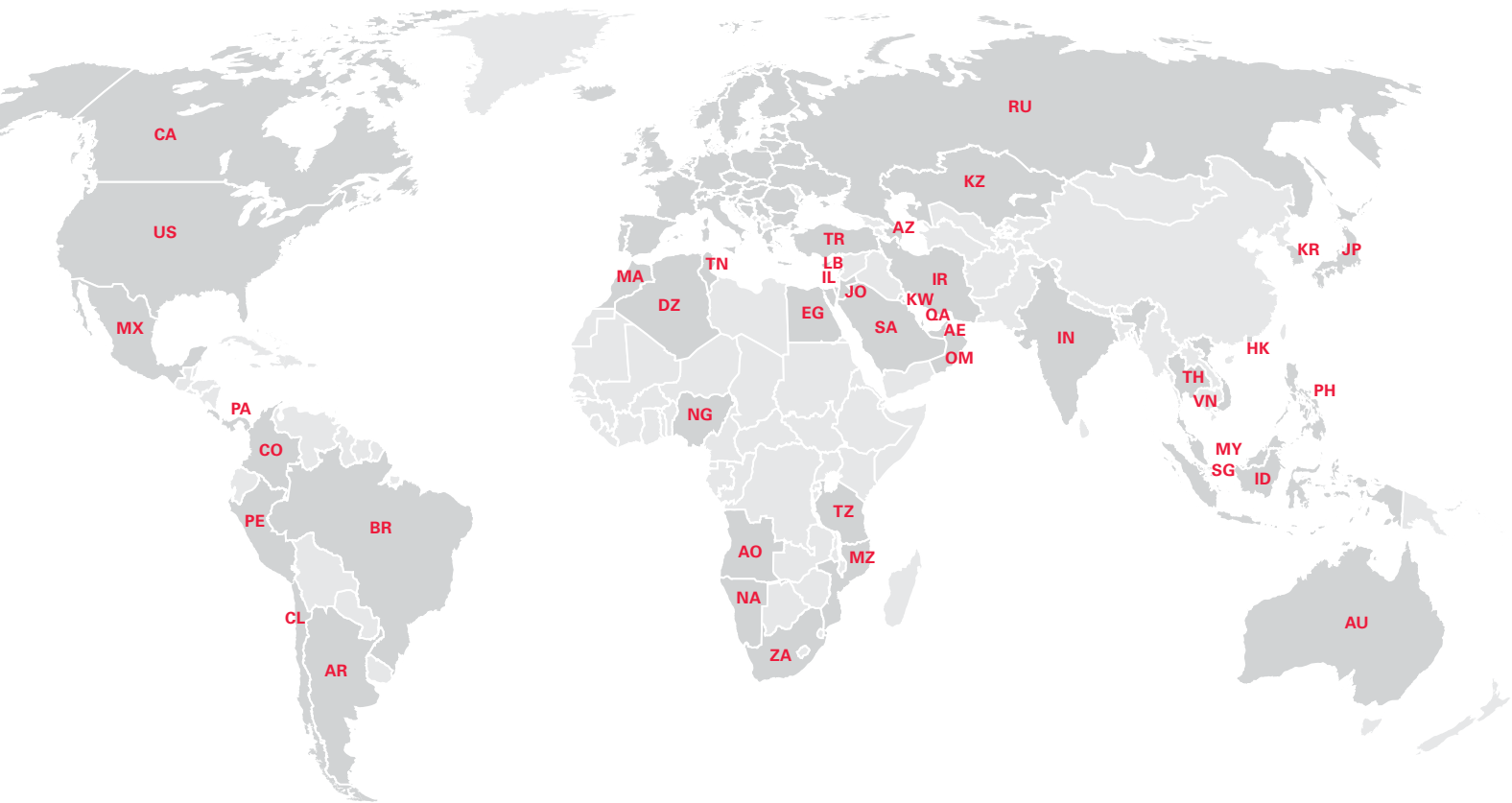

North America

- CA** Canada
PERI Formwork Systems, Inc.
www.peri.ca
- MX** Mexico
PERI Cimbras y Andamios, S.A. de C.V.
www.peri.com.mx
- PA** Panama
PERI Panama Inc.
www.peri.com.pa
- US** USA
PERI Formwork Systems, Inc.
www.peri-usa.com

South America

- AR** Argentina
PERI S.A.
www.peri.com.ar
- BR** Brazil
PERI Formas e Escoramentos Ltda.
www.peribrasil.com.br
- CL** Chile
PERI Chile Ltda.
www.peri.cl
- CO** Colombia
PERI S.A.S.
www.peri.com.co
- PE** Peru
PERI Peruana S.A.C.
www.peri.com.pe

Africa

- AO** Angola
Pericofragens, Lda.
www.peri.pt
- DZ** Algeria
S.A.R.L. PERI
www.peri.dz
- EG** Egypt
Egypt Branch Office
www.peri.com.eg
- MA** Morocco
PERI S.A.
www.peri.ma
- MZ** Mozambique
PERI (Pty.) Ltd.
www.peri.co.mz
- NA** Namibia
PERI (Pty.) Ltd.
www.peri.na
- NG** Nigeria
PERI Nigeria Ltd.
www.peri.ng
- TN** Tunisia
PERI S.A.U.
www.peri.es
- TZ** Tanzania
PERI Formwork and Scaffolding Ltd
www.peri.co.tz
- ZA** South Africa
PERI Formwork Scaffolding (Pty) Ltd
www.peri.co.za

Asia

- AE** United Arab Emirates
PERI (L.L.C.)
www.peri.ae
- AZ** Azerbaijan
PERI Representative Office
www.peri.com.tr
- HK** Hong Kong
PERI (Hong Kong) Limited
www.perihk.com
- ID** Indonesia
PT Beton Perkasa Wijaksana
www.betonperkasa.com
- IL** Israel
PERI F.E. Ltd.
www.peri.co.il
- IN** India
PERI (India) Pvt Ltd
www.peri.in
- IR** Iran
PERI Pars. Ltd.
www.peri.ir
- JO** Jordan
PERI GmbH – Jordan
www.peri.com
- JP** Japan
PERI Japan K.K.
www.peri.co.jp
- KR** Korea
PERI (Korea) Ltd.
www.perikorea.com
- KW** Kuwait
PERI Kuwait W.L.L.
www.peri.com.kw
- KZ** Kazakhstan
TOO PERI Kazakhstan
www.peri.kz
- LB** Lebanon
PERI Lebanon Sarl
lebanon@peri.de
- MY** Malaysia
PERI Formwork Malaysia Sdn. Bhd.
www.perimalaysia.com
- OM** Oman
PERI (L.L.C.)
www.peri.ae
- PH** Philippines
PERI-Asia Philippines, INC.
www.peri.com.ph
- QA** Qatar
PERI Qatar LLC
www.peri.qa
- SA** Saudi Arabia
PERI Saudi Arabia Ltd.
www.peri.com.sa
- SG** Singapore
PERI Asia Pte Ltd
www.periasia.com
- TH** Thailand
Peri (Thailand) Co., Ltd.
www.peri.co.th
- TR** Turkey
PERI Kalıp ve İskeleleri
www.peri.com.tr
- VN** Vietnam
PERI ASIA PTE LTD
www.peri.com.vn



PERI

**PERI GmbH
Formwork Scaffolding Engineering**

Rudolf-Diesel-Strasse 19
89264 Weissenhorn
Germany
Tel. +49 (0)7309.950-0
Fax +49 (0)7309.951-0
info@peri.com
www.peri.com

Oceania

AU Australia
PERI Australia Pty. Ltd.
www.periaus.com.au

DK Denmark
PERI Danmark A/S
www.peri.dk

IT Italy
PERI S.r.l.
www.peri.it

SE Sweden
PERI Sverige AB
www.peri.se

Europe

EE Estonia
PERI AS
www.peri.ee

LT Lithuania
PERI UAB
www.peri.lt

SI Slovenia
PERI oplate i skele d.o.o
www.peri.com.hr

AL Albania
PERI Kalıp ve İskeleleri
www.peri.com.tr

ES Spain
PERI S.A.U.
www.peri.es

LU Luxembourg
N.V. PERI S.A.
www.peri.lu

SK Slovakia
PERI spol. s. r.o.
www.peri.sk

AT Austria
PERI Ges.mbh
www.peri.at

FI Finland
PERI Suomi Ltd. Oy
www.perisuomi.fi

LV Latvia
PERI SIA
www.peri-latvija.lv

UA Ukraine
TOW PERI
www.peri.ua

BA Bosnia and Herzegovina
PERI oplate i skele d.o.o
www.peri.com.hr

FR France
PERI S.A.S.
www.peri.fr

NL Netherlands
PERI b.v.
www.peri.nl

BE Belgium
PERI N.V.
www.peri.be

GB United Kingdom
PERI Ltd.
www.peri.ltd.uk

NO Norway
PERI Norge AS
www.peri.no

BG Bulgaria
PERI Bulgaria EOOD
www.peri.bg

GR Greece
PERI Hellas Ltd.
www.perihellas.gr

PL Poland
PERI Polska Sp. z o.o.
www.peri.com.pl

BY Belorussia
IOOO PERI
www.peri.by

HR Croatia
PERI oplate i skele d.o.o.
www.peri.com.hr

PT Portugal
Pericofragens Lda.
www.peri.pt

CH Switzerland
PERI AG
www.peri.ch

HU Hungary
PERI Kft.
www.peri.hu

RO Romania
PERI România SRL
www.peri.ro

CZ Czech Republic
PERI spol. s r.o.
www.peri.cz

IR Ireland
Siteserv Access & Formwork
www.siteservaccess.ie

RS Serbia
PERI oplate d.o.o.
www.peri.rs

DE Germany
PERI GmbH
www.peri.de

IS Iceland
Armar ehf.
www.armor.is

RU Russia
OOO PERI
www.peri.ru

**The optimal System
for every Project and
every Requirement**



Wall Formwork



Column Formwork



Slab Formwork



Climbing Systems



Bridge Formwork



Tunnel Formwork



Shoring Systems



Construction Scaffold



Facade Scaffold



Industrial Scaffold



Access



Protection Scaffold



Safety Systems



**System-Independent Access-
ories**



Services



PERI GmbH
Formwork Scaffolding Engineering
 Rudolf-Diesel-Strasse 19
 89264 Weissenhorn
 Germany
 Tel. +49 (0)7309.950-0
 Fax +49 (0)7309.951-0
 info@peri.com
 www.peri.com