



PERI UP Rosett Flex – the heavy-duty prop

The economical solution for high loads – with hydraulic lowering and pre-tensioning

Cost-effective

Through the use of standard components from the PERI UP Rosett Flex modular scaffold product range

Controlled load reduction

Displacement and force-controlled lowering under load through the hydraulic cylinder in the base

Systematic pre-tensioning

Force-controlled pre-tensioning with the hydraulic cylinder e.g. for shoring in existing buildings



**Formwork
Scaffolding
Engineering**

www.peri.com

PERI UP Rosett Flex – the heavy-duty prop

The economical solution for high loads – with hydraulic lowering and pre-tensioning

The 4-legged heavy-duty prop is comprised of system components from the PERI UP modular scaffold range and carries concentrated loads of up to 200 kN. The hydraulic cylinder in the base allows displacement and force-controlled lowering under load as well as systematic force-controlled pre-tensioning. The PERI UP Rosett Flex heavy-duty prop is suitable for shoring operations with high concentrated loads particularly when shoring in existing buildings.



The hydraulic unit consists of a lifting cylinder and hand pump. The pressure gauge shows the pressure [bar] as well as the force [kN].



The head spindle provides an adjustment range of 55 cm and thus has the necessary flexibility for adapting to the condition of the building.

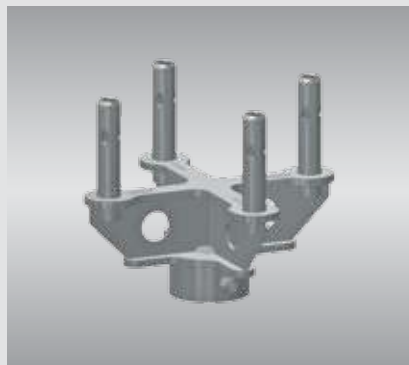

The connecting plate transfers the force into the lowering spindle. The integrated cap piece centres the loads and prevents constraint forces.

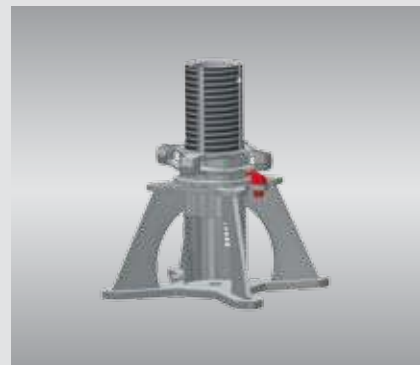

Through the locking device, the lowering spindle can be lowered a maximum 10 mm. This avoids any uncontrolled load redistribution.



**Formwork
Scaffolding
Engineering**

www.peri.com